

Simplex Cylinders Improve Manufacturing Efficiencies.

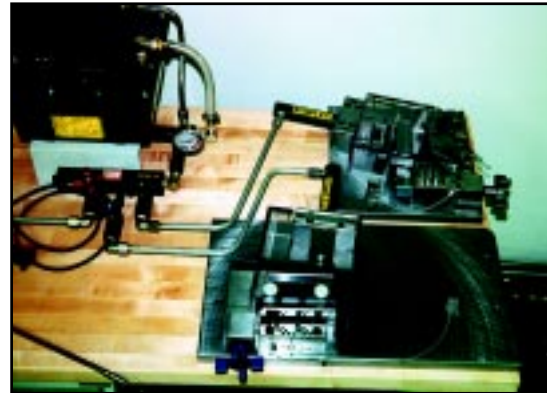

- 14 Models
- High flow quality couplers.
- Collar threads designed for full load.
- Base & piston mountings for easy fixturing.
- Removable load caps for flexibility & safety.
- Stop ring for piston blow-out protection.
- Plated piston to resist scoring & corrosion.
- Large bearings resist side load.
- Rod wiper protects inner cylinder from dirt.



Simplex spring return cylinders, used in this fabricating fixture, provide fast and accurate forming of precision metal products.

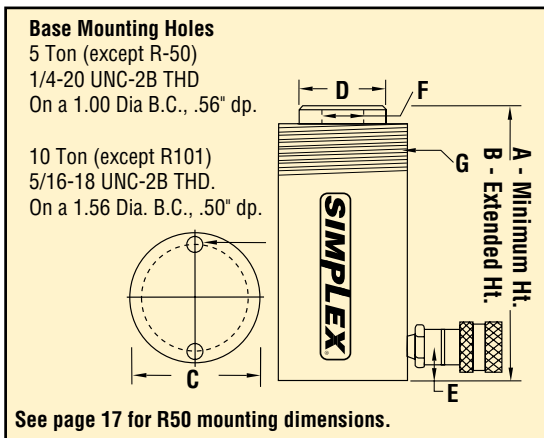

Cylinder Accs. pg. 11	Hoses pgs. 70-71	Bases pg. 11	Pump & Cylinder Sets pg. 30

Spring Return Cylinders 5 & 10 Ton Capacities

Model Number	Cap. (tons)	Stroke (in)	A Min. Ht. (in)	B Ext. Ht. (in)	Ram Bore Dia. (in)	Effect Area (sq in)	Pres. @ Cap. (psi)	Oil Cap. Req'd (cu in)	C Body O.D. (in)	D Piston O.D. (in)	E Base To Port C/L (in)	F		G		Wgt. (lbs)	Sugstd. Hand Pump
												Piston I.D. Thrds. (in)	Piston Thrd. Depth (in)	Collar Thrds. (in)	Collar Thrd. Lgth. (in)		
R50	5	5/8	1 5/8	2 1/4	1 1/8	.99	10,000	.6	1.6x2.3	1	3/4	None	None	None	None	2.5	P41
R51		1	4 11/32	5 11/32				1.0	2.5								
R53		3	6 1/2	9 1/2				3.0	3.3								
R55		5	8 1/2	13 1/2				5.0	4.0								
R57		7	10 5/8	17 5/8				7.0	5.0								
R59	9 1/8	12 3/4	21 7/8	9.1	5.5												
R101	10	1	3 17/32	4 17/32	1 11/16	2.24	8,945	2.2	2 1/4	1 1/2	3/4	None	None	1 1/8	3.5	P42	
R102		2 1/8	4 25/32	6 29/32				5.22				5.2					
R104		4 1/8	6 3/4	10 7/8				9.2				6.3					
R106		6 1/8	9 3/4	15 7/8				13.7				8.8					
R108		8	11 3/4	19 3/4				18.0				10.5					
R1010		10 1/8	13 3/4	23 7/8				22.7				12.0					
R1012		12	15 3/4	27 3/4				27.0				13.5					
R1014		14	17 3/4	31 3/4				31.5				15.3					

SPRING RETURN - 15-25 TON

CYLINDERS

Simplex Cylinders Are Perfect For Heavy Maintenance.



- 13 Models
- High flow quality couplers.
- Collar threads designed for full load.
- Base & piston mountings for easy fixturing.
- Removable load caps for flexibility & safety.
- Stop ring for piston blow-out protection.
- Plated piston to resist scoring & corrosion.
- Large bearings resist side load.
- Rod wiper protects inner cylinder from dirt.



Large steel coils that were damaged in handling are reshaped using a Simplex R256 cylinder and PE70 Series pump.

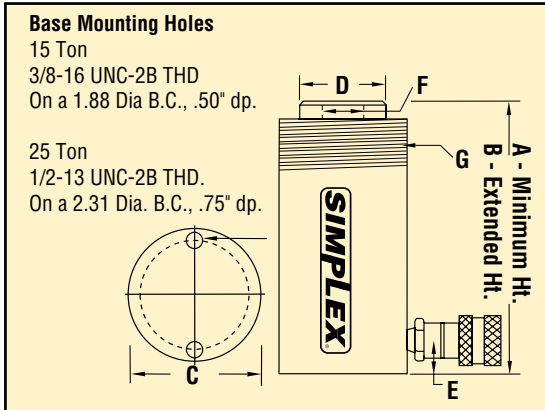

Cylinder Accys. pg. 11	Hoses pgs. 70-71	Bases pg. 11	Pump & Cylinder Sets pg. 30

Spring Return Cylinders 15 & 25 Ton Capacities

Model Number	Cap. (tons)	Stroke (in)	A Min. Ht. (in)	B Ext. Ht. (in)	Ram Bore Dia. (in)	Effect Area (sq in)	Pres. @ Cap. (psi)	Oil Cap. Req'd (cu in)	C Body O.D. (in)	D Piston O.D. (in)	E Base To Port C/L (in)	F		G		Wgt. (lbs)	Sugstd. Hand Pump
												Piston I.D. Thrds. (in)	Piston Thrd. Depth (in)	Collar Thrds. (in)	Collar Thrd. Lgth. (in)		
R152	15	2	5 7/8	7 7/8	2	3.14	9,554	6.3	2 3/4	15/8	3/4	1 x 8	1	23/4 x 16	1 3/16	8.3	P42
R154		4	7 7/8	11 7/8				12.6								10.8	
R156		6	10 11/16	16 11/16				19.0								14.5	
R1510		10	14 11/16	24 11/16				31.4								19.5	
R1514		14	18 11/16	32 11/16				44.0								24.5	
R251	25	1	5 1/2	6 1/2	2 9/16	5.15	9,700	5.2	3 3/8	2 1/4	1	1 1/2 x 16	1 1/8	35/16x12	1 15/16	12.0	P42
R252		2	6 1/2	8 1/2				10.3								15.0	
R254		4	8 1/2	12 1/2				20.6								18.0	
R256		6 1/4	10 3/4	17				32.2								23.0	
R258		8 1/4	12 3/4	21				42.5								27.0	
R2510		10 1/4	14 3/4	25				52.8								31.0	
R2512		12 1/4	16 3/4	29				63.1								35.0	
R2514		14 1/4	18 3/4	33				73.4								39.0	

CYLINDERS

SPRING RETURN - 30-100 TON

Simplex Cylinders Help Stand Up To Tough Construction Jobs.



- 9 Models
- High flow quality couplers.
- Collar threads designed for full load.
- Base & piston mountings for easy fixturing.
- Removable load caps for flexibility & safety.
- Stop rings for piston blow-out protection.
- Plated piston to resist scoring & corrosion.
- Large bearings resist side load.
- Rod wiper protects inner cylinder from dirt.
- Removable carrying handles included on models R556 through R10010.



Contractors called on the brute force of Simplex R5513 cylinders to lift and position highway ramps in San Diego. PE50 power units provided the power and control in this rough outdoor application.

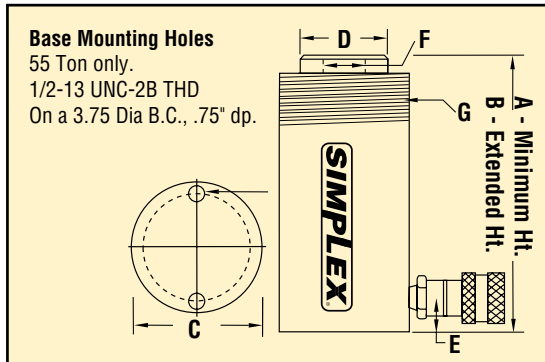

		
Power Pumps pgs. 39-62	Hoses pgs. 70-71	Cylinder Accessories pg. 11

Spring Return Cylinders 30 Through 100 Ton Capacities

Model Number	Cap. (tons)	Stroke (in)	A Min. Ht. (in)	B Ext. Ht. (in)	Ram Bore Dia. (in)	Effect Area (sq in)	Pres. @ Cap. (psi)	Oil Cap. Req'd (cu in)	C Body O.D. (in)	D Piston O.D. (in)	E Base To Port C/L (in)	F		G		Wgt. (lbs)	Sugstd. Hand Pump
												Piston I.D. Thrds. (in)	Piston Thrd. Depth (in)	Collar Thrds. (in)	Collar Thrd. Lgth. (in)		
R308	30	8 1/4	15 1/4	23 1/2	2 7/8	6.49	9,245	53.6	4	2 1/4	2 1/4	1 1/2 x 16	1 3/16	35/16x12	1 15/16	40.0	P82
R552		2	6 15/16	8 15/16				22.1									
R554	55	4	8 15/16	12 15/16	3 3/4	11.05	9,955	54.0	5	3 1/8	1 3/8	N/A	N/A	5 x 12	2 1/8	42.0	P82
R556		6 1/4	11 1/8	17 3/8				69.0								50.0	
R5513		13 1/4	18 1/8	31 3/8				146.3								78.0	
R756	75	6 1/8	11 1/4	17 3/8	4 1/2	15.90	9,430	97.4	5 3/4	3 3/4	1 3/16	N/A	N/A	53/4 x 12	1 3/4	63.0	*
R7513		13 1/8	19 3/8	32 1/2				208.0								130.0	
R1006	100	6 5/8	13 1/4	20 11/16	5 1/8	20.63	9,695	137.0	6 1/4	4 1/8				61/4 x 12	2 1/4	90.0	
R10010		10 1/4	16 7/8	27 15/16				212.0								110.0	

*Power pumps are suggested for these units (see pages 39-62)